

RAD5545™ SpaceVPX

Multi-core single-board computer

The RAD5545™ SpaceVPX singleboard computer (SBC) integrates the version 1.2 RAD5545 system-on-chip (SoC) processor with volatile and non-volatile memory on a 6U-220 format module compliant to the ANSI/VITA 78.00 SpaceVPX standard.

The SBC is designed to support operation as either a payload or system controller in a SpaceVPX backplane. Based on BAE Systems' RAD5545 or RAD5515 QorIQ® Power Architecture® radiation-hardened SoC processor, the SBC offers both high performance and high I/O throughput.

It includes 4 GBytes of DDR3 SDRAM with error correction at 800 MTransfers/second and 1 GBytes of triple modular redundant non-volatile flash memory and optional 4MB MRAM. Up to four RapidIO ports at 10 Gbits/second each and 12 SpaceWire links at 320 Mbits/second each are provided to the SpaceVPX backplane. An optional daughter card with PCI, RapidIO, and/or SpaceWire interfaces can be used to personalize the SBC for unique needs.

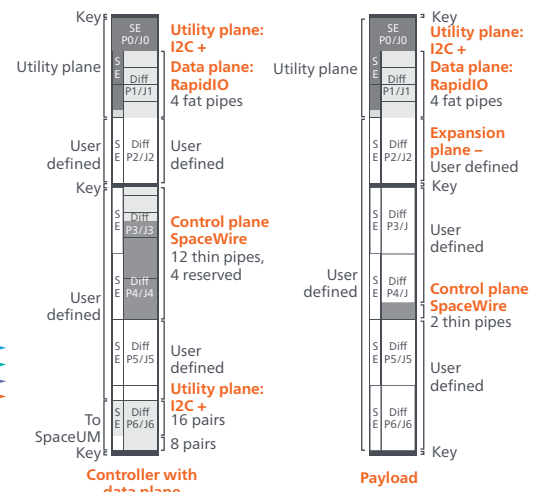
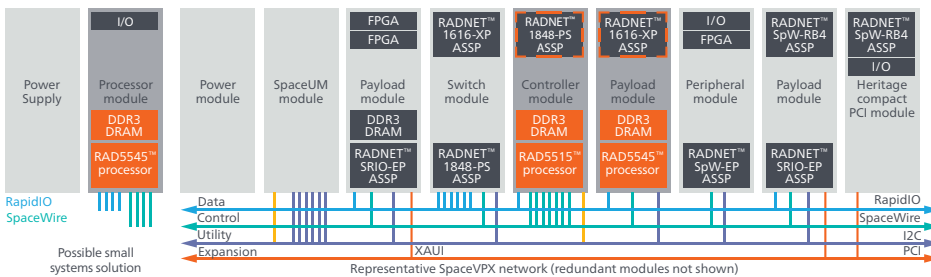
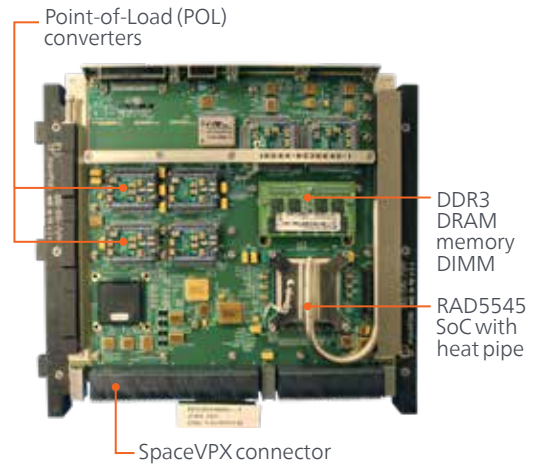

Key features and benefits

- Processor throughput of up to 5.6 giga-operations per second/3.7 giga-floating-point operations per second offers more than 10 times the performance of the fastest RAD750® processor
- Memory bandwidth of up to 51 Gb/s and I/O throughput of up to 40 Gb/s provide balance to prevent bottlenecks to or from the processor cores
- Dual in-line memory module mounting supports ease of memory replacement or upgrade
- Optional user-personalized daughter card with parallel peripheral component interconnect, RapidIO, and/or SpaceWire interfaces supports mission-specific SBC personalization
- Designed for insertion into the SpaceVPX backplane, supporting the RapidIO data plane, SpaceWire control plane, and system management inter-integrated circuit utility plane for interoperability with other SpaceVPX-compliant boards
- Multiple levels of on-die cache and high-performance DDR3 main memory all with error correction provide maximum effective throughput and reliability
- Triple modular redundant (TMR) flash memory and optional MRAM enables high-density, non-volatile storage with high reliability
- Trust architecture security infrastructure provides secure boot, integrity code testing, data encryption, and partitioning of the system to minimize the likelihood of corruption due to intentional or environmental-based intrusion
- Up to four RapidIO ports with integrated message managers support high-performance data streaming and messaging and support system architectures based on either mesh or switch-based backplanes

Hardware block diagram

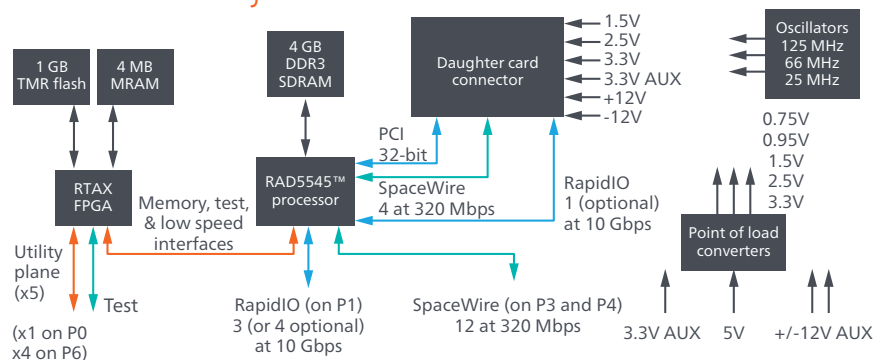

Specifications

SpaceVPX	Slot profiles: payload, system controller with data plane Module profiles: Payload: MOD6-PAY-4F1Q2T-12.2.1-5-22 Controller: MOD6-CON-4F12T12U-12.6.1-2-22 Mechanical size: 6U-220 Card pitch: 1.2 inches Cooling: Conduction Power profile (no daughter card) 5.0V (+/- 10 percent): 6.7 Amps 3.3V AUX: <1.0 Amps User-defined I/O: Differential
Temperature	Operating at -55 to 125 degrees Celsius
Radiation-hardness	Total ionizing dose: 100 Krad (Si) Single event upset: 1 e-3 upsets/card-day Latchup immune
Power dissipation	35 Watts at 95 degrees Celsius and +5 percent voltage with all dissipation interfaces operational (no daughter card)
Interfaces	Up to four 4-lane RapidIO ports up to 3.125 Gbaud/lane (also supports 2.5, and 1.25 Gbaud/lane) Up to 12 SpaceWire serial links to the backplane up to 320 Mb/s each I2C and related utility plane control signals JTAG test and debug Aurora high speed trace debug
Daughter card interfaces	Up to 4 SpaceWire links One RapidIO port (the RapidIO port is mutually exclusive with the 4th RapidIO port to the backplane) 32-bit parallel PCI

For more information contact:

Sean O'Brien
9300 Wellington Road
Manassas, Virginia 20110-4122
T: 571 364 7777
E: sean.obrien2@baesystems.us
W: baesystems.com/spaceelectronics

Cleared for open publication on 03/17

Disclaimer and copyright

BAE Systems reserves the right to restrict component sales based on application and volume. Please contact the factory for more information.

This document gives only a general description of the product(s) and service(s) and, except where expressly provided otherwise, shall not form any part of any contract. From time to time, changes may be made in the products or the conditions of supply.

BAE SYSTEMS is a registered trademark of BAE Systems plc.
© 2025 BAE Systems. All rights reserved.
CS-17-C09_v1.2