

Unbeatable Survivability

- Unparalleled tactical and strategic mobility
- Low thermal and radar signatures
- Rapid emplacement/displacement
- Ultra-low silhouette
- World's first 155mm Howitzer weighing less than 10,000 lbs

Lightweight Field
Howitzer 155

M777

baesystems.com

Mobile forces require quality systems that are quick and easy to transport. Through the innovative use of titanium and aluminium alloys, the M777 is rapidly deployable and consistently accurate.

Highly portable by land, sea and air, the system features a minimal logistical footprint alongside maximum reliability. This means that it can be frequently moved and re-deployed, maximizing survivability, without encountering the IED risks faced by self-propelled systems. The weapon can strike over extended distances, regardless of terrain and obstacles. It is compatible with all standard ammo types, as well as advanced rounds such as BONUS and EXCALIBUR. Its strengths have been proven in battle,

particularly in Afghanistan where it has been in service since 2006. Over 360,000 rounds fired have proven its simple, dependable operation, even in harsh environments.

Development and Production

Initially developed for the U.S. Marine Corps and the U.S. Army as their next generation Medium Force weapon, the M777 has become the benchmark for 155mm Lightweight Towed

Artillery Systems. To date, the system has been selected by U.S., Canadian, Australian, and Indian forces, with total orders currently exceeding 1,200.

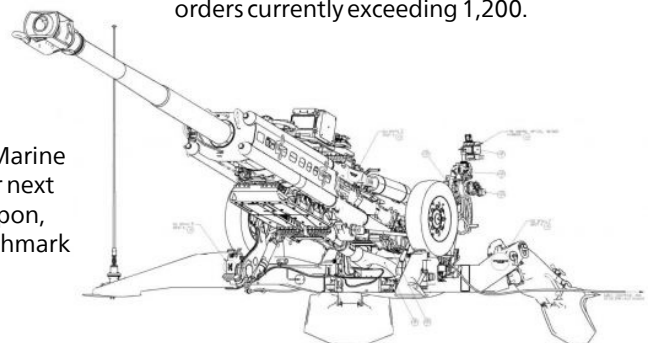

The 39 caliber M777 sets the standard for modern, reliable fire support in the most hostile environments.



Technical Data

Range

- Maximum unassisted: 24.7 km
- Maximum assisted: 30+ km

Rate of fire

- Intense: 4 rounds per minute for up to 2 minutes
- Sustained: 2 rounds per minute

Into/out of action

- Emplacement: < 3 minutes
- Displacement: 2 - 3 minutes

Pointing limits

- Elevation: +1,275 mm
- Depression: -43 mm
- Traverse (on carriage): 400 mils left and right (6,400 mils through quickswitch)

Ammunition

- All current and developmental U.S. and NATO standard 155mm projectiles and charges including Modular Artillery Charge System

Mobility

- Maximum road speed: 88 kph/55 mph
- Cross country speed: 24 kph/15 mph
- Towing vehicles: MTRV, FMTV, M800 and M900 5 ton trucks, any 2.5 ton truck
- Fixed wing: C130, C141, C17, C5, Roll-on roll-off/LVAD
- Rotary wing: CH53E, CH47D, MV22

BAE Systems, Inc.

Platforms & Services
baesystems.com

For more information contact

platforms.services@baesystems.com

Disclaimer and copyright

This document gives only a general description of products and services and except where expressly provided otherwise shall not form part of any contract. From time to time, changes may be made in the products or conditions of supply.

© BAE SYSTEMS. All rights reserved.

The information contained in this document is proprietary to BAE SYSTEMS unless stated otherwise and is made available in confidence; it must not be used or disclosed without the express written permission of BAE SYSTEMS. This document may not be copied in whole or in part in any form without the express written consent of BAE SYSTEMS which may be given by contract.

BAE SYSTEMS is a registered trade mark of BAE Systems plc.

1.25.M777.BTR

Approved for public release 2017-08.