

# Radiation-hardened DDR3L SRAM products

## Ultra-high-speed memory products

The monolithic static random-access memory (SRAM) bit cell array coupled with a double data rate third generation low voltage (DDR3L) synchronous dynamic random-access memory (SDRAM) interface is BAE Systems' next generation RHBD (Rad Hard by Design), ultra-high-speed memory product for users in the space community.

Capable of withstanding the effects of natural space and an upper radiation hardened environment, the monolithic SRAM DDR3L SDRAM has a total-dose tolerance of greater than 300Krad and an upset rate of less than  $1E-12$  upsets per bit-day.



Pre-production 1Gb SRAM in side-by-side two die format

## Key features

- Transfer rate of 800 MT/s
- Operating temperature range -55 °C to 110 °C
- Operating voltage (core) of  $0.80 \pm 0.5V$
- Operating voltage (I/O) of  $1.35 \pm 0.5V$
- RHBD 12nm Bulk FinFET CMOS
- On Die Error Detection and Correction (EDAC)
- 1GB Packaging 201-pin Hermetic Ceramic Column Grid Array (CCGA) and 2GB Packaging 237-pin Plastic Ball Grid Array (PBGA)
- Synchronous operation
- Prototype and flight flows
- Immune to Latchup and SEFI
- Only RHBD DDR3 Memory on the market

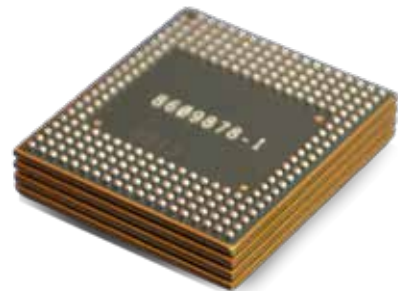

Pre-production 2Gb SRAM in stacked, four die format

## System definitions

**BA:** 0-2 BA(2:0) define the bank to which an ACTIVATE, READ, WRITE, or PRECHARGE command is being applied. BA(2:0) define which mode register is loaded during the MODE REGISTER SET command.

**A:** 0-12 Address pins provide the row address for ACTIVATE commands, and the column address and auto precharge bit (10) for READ/WRITE commands, to select one location out of the memory array in a respective bank.

**CS\_L:** 0-1 Enables (registered LOW) and disables (registered HIGH) the command decoder. All commands are masked when CS\_L is registered HIGH. One per die (die 0 and die 1).

**RAS\_L, CAS\_L, WE\_L:** Command inputs to the command decoder used to specify the various commands.

**DQ:** 0-7 Bi-directional data pins that serve as data outputs during a READ command and as data inputs during a WRITE command.

**DQS\_P, DQS\_N:** Bi-directional data strobe that are edge-aligned output with read data and center aligned input with write data.

**CKE:** 0-1 Enables (registered HIGH) and disables (registered LOW) internal circuitry and clocks on the SDRAM.

**RESET\_L** is an active low CMOS input. RESET\_L assertion and desertion are asynchronous.

**SEL\_PRECH\_ENA:** When high, the selective precharge function is enabled—internal RAM RET1N pins are set to '1' when selected by an ACTIVE command and set to '0' by a PRECHARGE or AUTO PRECHARGE command.

**SEL\_PRECH\_ENA:** When high, the selective precharge function is enabled—internal RAM RET1N pins are set to '1' when selected by an ACTIVE command and set to '0' by a PRECHARGE or AUTO PRECHARGE command.

**DM:** An input mask signal for write data. Input data is masked when DM is sampled HIGH along with the input data during a write access.

**CLK\_P, CLK\_N:** Differential clock inputs that sample all control and address input signals upon the crossing of the positive edge of CLK\_P and the negative edge of CLK\_N.

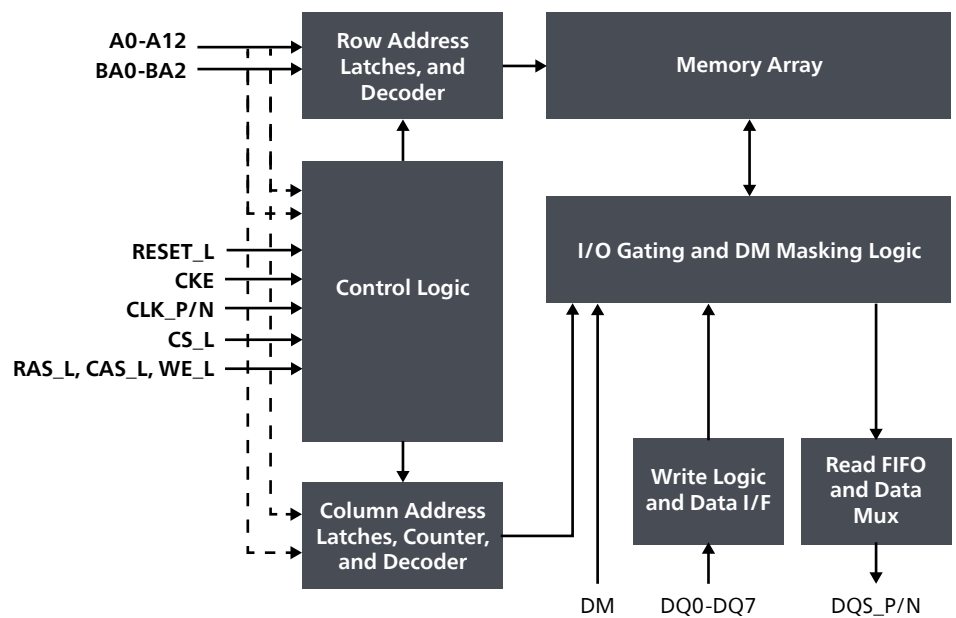

## Specifications

1GB and 2Gb SRAM DDR3L SDRAM operation family of products

512 Gb single chip (die), up to 2 Gb multi-chip module (MCM) is available in  
 – 128M x 8 (MCM) (1 Gb)  
 – 64M x 32 (MCM) (2 Gb)

### For more information contact:

BAE Systems  
 Sean O'Brien  
 9300 Wellington Road  
 Manassas, Virginia 20110-4122

**T:** 703 789 1489

**W:** baesystems.com/spaceelectronics

Cleared for open publication on **06/25**

Not export controlled per ES-C4ISR-053025-0151

### Disclaimer and copyright

BAE Systems reserves the right to restrict component sales based on application and volume. Please contact the factory for more information.

This document gives only a general description of the product(s) and service(s) and, except where expressly provided otherwise, shall not form any part of any contract. From time to time, changes may be made in the products or the conditions of supply.

BAE SYSTEMS is a registered trademark of BAE Systems plc.  
 © 2025 BAE Systems. All rights reserved.  
 CS-25-B62