

FMTV A1 R M1089 A1

5.0 ton Wrecker

The Family of Medium Tactical Vehicles (FMTV) provides the U.S. Army's backbone for tactical unit mobility and logistics support throughout the battlefield. These vehicles are considered the most sophisticated off-road, multi-purpose military tactical vehicles in use, and are capable of operating worldwide on primary and secondary roads, as well as on trails and cross-country in weather extremes from -50°F (-46°C) to +120°F (49°C).

Product Numbers
 LIN T94709
 NSN 2320-01-447-3892

KEY FEATURES

- Full-time all-wheel drive
- Fully automatic transmission
- Electronic Central Tire Inflation System (CTIS)
- Anti-lock Braking System (ABS)
- Interactive Electronic Technical Manuals (IETM)
- Fully MANPRINT compliant
- C-130 air transportable at GVW
- U.S. Army proven ultra-reliability
- Family of 16+ vehicles with 80% commonality
- U.S. Army certified 22-year corrosion protection
- Highest proven reliability of any tactical vehicle

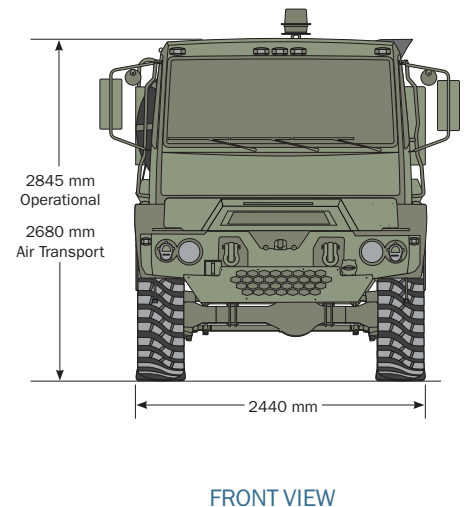
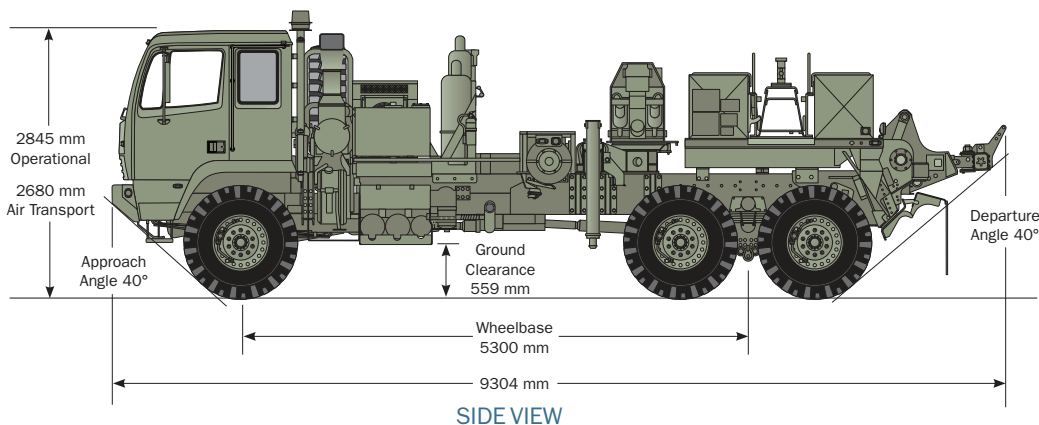

FMTV A1 R M1089 A1

5.0 ton Wrecker

VEHICLE SPECIFICATIONS

Length:	366 in (9,304 mm)
Width:	96 in (2,438 mm)
Height:	
Operational	112 in (2,845 mm)
For Air Transport	105.5 in (2,680 mm)
Wheel Base:	209 in (5,300 mm)
Ground Clearance:	
Loaded	22 in (559 mm)
Under Axle	14.4 in (365 mm)
Approach/Departure Angle:	40°/40°
Vehicle Curb Weight with Fuel:	35,172 lb (15,954 kg)
Payload, Lift Capacity:	11,000 lb (4,990 kg) plus kits
Towed Load:	36,000 lb (16,330 kg)
Maximum Speed:	
Governed, at Gross Weight	58 mph (94 km/h)
Range, 78 gal (295 L) nominal:	300+ mi (483+ km)
Maximum Grade/Side Slope:	60%/30%
Turning Circle:	
Curb-to-Curb	77 ft (23.5 m)
Wall-to-Wall	83 ft (25.3 m)
Fording, without Kit:	30 in (762 mm)

EQUIPMENT SPECIFICATIONS

Cab:	
Design	3-Man, Ergonomically Adjustable Driver Seat and Steering Wheel
Steering	Power Assisted, Recirculating Ball
Storage	8 cu ft
Suspension	3-Point Rubber Isolator
Engine:	
Caterpillar C7	Heavy Duty Diesel, 6-Cylinder, Electronic Controlled, Fuel-Injected Turbocharged and Aftercooled, EPA Certified
Rating	330 hp (246 kW) @ 2400 rpm
Displacement	441 cu in (7.2 L)
Torque	860 lb-ft (1,166 Nm) @ 1440 rpm
Fuel	Diesel, DF-2, JP-4, JP-8, VV-F-800
Oil	MIL-L-2104D, MIL-L-46167, 22 qt (21 L)
Transmission:	
Allison 3700SP	Automatic/Select 7-speed, Electronically Controlled
Full-Time All-Wheel Drive	Integral Transfer Case
Normal Operation	30% Torque Front Wheels, 70% Torque Rear Wheels; Off-Road, Equal Front and Rear
Oil	MIL-L-2104D, MIL-L-46167, 31.8 qt (30 L)
Axles:	
ArvinMeritor	Front, Intermediate and Rear Axles
Carrier	Single Reduction, Amboid-Gearing
Wheel End	Bevel Wheel End Reduction, Ratio 2:1
Overall Axle Gear Ratio	7.8:1
Front Axle Steering Angle	35°
Electrical:	
System	12/24 volt, EMI/HAEMP Qualified, Resettable Circuit Breakers, Central Power Distribution Panel, Battery and Charging Management System
Alternator	260 amp, 12/24 volt, Waterproof, EMI/RFI Suppressed
Starter	24 volt Waterproof
Instrumentation	SAE J1708 Data Bus Driven Instrument Cluster
Tires:	Michelin 395/85R20XML All-Terrain

Brakes:	
Primary	Dual-Circuit, Four Channel Air, Anti-Lock Braking System (ABS) with Trailers ABS Connectors for Emergency Towing
Supplemental	Air Actuated, Driver Controlled Exhaust Brake
Central Tire Inflation System, Eaton:	
	Cab-Mounted Electronic Controls, Operable while Driving Highway, Cross-Country, Air Transport, Sand/Mud/Snow, and Emergency Modes
Diagnostics, Interactive Electronic Technical Manuals (IETM):	
	Class V, Intrusive Diagnostics, SAE J1708/J1939 Data Buses to Diagnose All (4) Unique Electronic Control Modules (ECM)
Suspension:	
Front	Parabolic-Tapered Leaf Spring with Coil over Hydraulic Shock Absorbers
Rear	Tandem Axles with Parabolic-Tapered Leaf Spring with Hydraulic Shock Absorbers and Stabilizer Bar
Transportability/Deployability:	
Internally	Air-transportable by C-130, C-141, C-17, and C-5A at GVW
Self Recovery Winch:	
(Standard)	15,500 lb (7,031 kg) Rating, 280 ft (85.3 m) Line Capacity, Fore Self Recovery Position; Main Recovery Winch Used for Aft Self Recovery Position
Wrecker Components:	
Lift and Tow	Provides Front or Rear Recovery of Disabled Vehicles, 11,000 lbs (4,990 kg) Lifting Capacity for Most Wheeled Military Vehicles
Main Recovery Winch	2 x 30,000 lb (13,608 kg) Line Pull Capacity
Material Handling Crane	
	Hydraulic Operation, 270° Rotation, 6,500 lb (2,948 kg) Lift at 18 ft (5.5 m), 11,000 lb (4,990 kg) Lift at 7 ft (2.1 m), Includes Stabilizers and Local/Remote Controls

FOR MORE INFORMATION CONTACT:

BAE Systems
 5000 I-10 West
 Sealy, TX 77474 USA
 Telephone 281-856-0139
 Toll Free 800-221-3688
 Fax 713-867-1688
 Email sales.mhv@baesystems.com
 www.baesystems.com

This document gives only a general description of the product(s) or services and except where expressly provided otherwise shall not form part of any contract. From time to time, changes may be made in the products or the conditions of supply. BAE Systems reserves the right to change product specifications without prior notice.